

PERFILES ABIERTOS CONFORMADOS EN FRÍO PERFIL LF. (UNE 36-571-79)

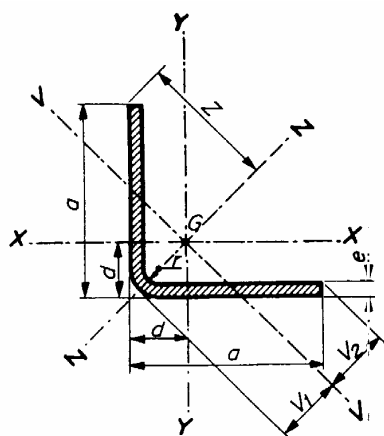

Siendo:

- A = Area de la sección recta.
- M = Masa por metro.
- I = Momento de inercia (referido al eje correspondiente de flexión).
- W = Momento resistente (referido al eje correspondiente de flexión).
- $\sqrt{I/A}$ = Radio de giro (referido al eje correspondiente de flexión).
- e = Distancia del centro de gravedad a la cara exterior.
- u = Perímetro (superficie por metro lineal).

Perfiles abiertos normalizados - Perfil L de alas iguales – Medidas

PERFIL	Dimensiones			A cm ²	M kg/m	u m ² /m	Distancia de los ejes			
	a mm	e mm	r mm				d cm	V ₁ cm	V ₂ cm	Z cm
LF 20 . 1.5	20	1.5	1.6	0.562	0.441	0.0780	0.570	0.678	0.714	1.41
LF 20 . 2.0	20	2.0	2.5	0.730	0.573	0.0770	0.596	0.657	0.712	1.41
LF 20 . 3.0	20	3.0	3.0	1.05	0.826	0.0761	0.641	0.657	0.720	1.41
LF 25 . 1.5	25	1.5	1.6	0.712	0.559	0.0980	0.695	0.854	0.891	1.77
LF 25 . 2.0	25	2.0	2.5	0.930	0.730	0.0970	0.721	0.833	0.890	1.77
LF 25 . 2.5	25	2.5	2.5	1.15	0.901	0.0968	0.741	0.841	0.897	1.77
LF 25 . 3.0	25	3.0	3.0	1.35	1.06	0.0961	0.765	0.833	0.898	1.77
LF 30 . 1.5	30	1.5	1.6	0.862	0.677	0.118	0.820	1.03	1.07	2.12
LF 30 . 2.0	30	2.0	2.5	1.13	0.887	0.117	0.845	1.01	1.07	2.12
LF 30 . 2.5	30	2.5	2.5	1.40	1.10	0.117	0.866	1.02	1.07	2.12
LF 30 . 3.0	30	3.0	3.0	1.65	1.30	0.116	0.889	1.01	1.08	2.12
LF 30 . 4.0	30	4.0	6.0	2.10	1.65	0.113	0.953	0.934	1.06	2.12
LF 40 . 2.0*	40	2.0	2.5	1.53	1.20	0.157	1.10	1.36	1.42	2.83
LF 40 . 3.0*	40	3.0	3.0	2.25	1.77	0.156	1.14	1.36	1.43	2.83
LF 40 . 4.0*	40	4.0	6.0	2.90	2.28	0.153	1.20	1.28	1.41	2.83
LF 50 . 2.0*	50	2.0	3.0	1.93	1.51	0.197	1.35	1.70	1.77	3.54
LF 50 . 3.0*	50	3.0	6.0	2.81	2.21	0.194	1.41	1.62	1.76	3.54
LF 50 . 4.0*	50	4.0	8.0	3.67	2.88	0.191	1.46	1.57	1.75	3.54
LF 60 . 3.0*	60	3.0	6.0	3.41	2.68	0.234	1.66	1.97	2.11	4.24
LF 60 . 4.0*	60	4.0	8.0	4.47	3.51	0.231	1.71	1.92	2.10	4.24
LF 60 . 5.0*	60	5.0	10.0	5.48	4.30	0.229	1.77	1.88	2.10	4.24
LF 80 . 4.0*	80	4.0	8.0	6.07	4.76	0.311	2.21	2.63	2.82	5.66
LF 80 . 5.0*	80	5.0	10.0	7.48	5.87	0.309	2.26	2.58	2.81	5.66
LF 80 . 6.0*	80	6.0	12.0	8.85	6.95	0.307	2.32	2.54	2.80	5.66
LF 100 . 5.0*	100	5.0	8.0	9.52	7.48	0.391	2.75	3.35	3.54	7.07
LF 100 . 6.0*	100	6.0	10.0	11.3	8.87	0.389	2.80	3.30	3.53	7.07
LF 100 . 7.0*	100	7.0	12.0	13.0	10.2	0.387	2.86	3.25	3.53	7.07
LF 120 . 5.0*	120	5.0	8.0	11.5	9.05	0.471	3.25	4.06	4.24	8.49
LF 120 . 6.0*	120	6.0	10.0	13.7	10.8	0.469	3.30	4.01	4.24	8.49
LF 120 . 7.0*	120	7.0	12.0	15.8	12.4	0.467	3.36	3.96	4.24	8.49

(*) Perfil utilizable en edificación.

Perfiles abiertos normalizados - Perfil L de alas iguales – Momentos

PERFIL	Referencia al X-X=Y-Y			I_{xy} cm ⁴	Referido al eje Z-Z			Referido al eje V-V		
	$I_x=I_y$ cm ⁴	$W_x=W_y$ cm ³	$i_x=i_y$ cm		I_z cm ⁴	W_z cm ³	i_z cm	I_v cm ⁴	W_v cm ³	i_v cm
LF 20 . 1.5	0.219	0.153	0.625	0.138	0.357	0.252	0.797	0.0819	0.115	0.382
LF 20 . 2.0	0.279	0.199	0.618	0.179	0.458	0.324	0.792	0.0995	0.140	0.369
LF 20 . 3.0	0.384	0.282	0.604	0.251	0.635	0.449	0.777	0.133	0.184	0.355
LF 25 . 1.5	0.440	0.244	0.786	0.273	0.714	0.404	1.00	0.167	0.187	0.484
LF 25 . 2.0	0.565	0.317	0.779	0.358	0.923	0.522	0.996	0.207	0.233	0.472
LF 25 . 2.5	0.684	0.389	0.772	0.434	1.12	0.633	0.987	0.250	0.279	0.467
LF 25 . 3.0	0.792	0.456	0.765	0.509	1.30	0.736	0.981	0.283	0.315	0.458
LF 30 . 1.5	0.774	0.355	0.947	0.478	1.25	0.590	1.20	0.296	0.277	0.586
LF 30 . 2.0	1.00	0.464	0.941	0.627	1.63	0.767	1.20	0.373	0.349	0.574
LF 30 . 2.5	1.22	0.570	0.934	0.765	1.98	0.935	1.19	0.452	0.421	0.569
LF 30 . 3.0	1.42	0.672	0.927	0.901	2.32	1.09	1.18	0.518	0.481	0.560
LF 30 . 4.0	1.75	0.855	0.912	1.18	2.93	1.38	1.18	0.574	0.544	0.523
LF 40 . 2.0*	2.44	0.841	1.26	1.51	3.96	1.40	1.61	0.928	0.653	0.779
LF 40 . 3.0*	3.52	1.23	1.25	2.20	5.71	2.02	1.59	1.32	0.920	0.765
LF 40 . 4.0*	4.43	1.58	1.24	2.89	7.32	2.59	1.59	1.55	1.09	0.730
LF 50 . 2.0*	4.85	1.33	1.59	3.00	7.85	2.22	2.02	1.85	1.04	0.980
LF 50 . 3.0*	6.97	1.94	1.57	4.44	11.4	3.23	2.01	2.52	1.44	0.947
LF 50 . 4.0*	8.92	2.52	1.56	5.82	14.7	4.17	2.00	3.09	1.77	0.919
LF 60 . 3.0*	12.3	2.83	1.90	7.74	20.0	4.72	2.42	4.54	2.15	1.15
LF 60 . 4.0*	15.8	3.69	1.88	10.2	26.0	6.13	2.41	5.66	2.69	1.12
LF 60 . 5.0*	19.1	4.52	1.87	12.5	31.7	7.46	2.40	6.59	3.14	1.10
LF 80 . 4.0*	38.8	6.70	2.53	24.5	63.3	11.2	3.23	14.3	5.09	1.54
LF 80 . 5.0*	47.3	8.25	2.52	30.3	77.6	13.7	3.22	17.1	6.07	1.51
LF 80 . 6.0*	55.4	9.74	2.50	35.9	91.3	16.1	3.21	19.4	6.94	1.48
LF 100 . 5.0*	95.1	13.1	3.16	59.4	155	21.9	4.03	35.7	10.1	1.94
LF 100 . 6.0*	112	15.5	3.15	70.7	183	25.8	4.02	41.2	11.7	1.91
LF 100 . 7.0*	128	17.9	3.13	81.8	210	29.7	4.01	46.2	13.1	1.88
LF 120 . 5.0*	167	19.1	3.81	104	270	31.9	4.84	63.4	14.9	2.34
LF 120 . 6.0*	197	22.7	3.79	123	320	37.8	4.84	73.8	17.4	2.32
LF 120 . 7.0*	226	26.2	3.78	143	369	43.5	4.83	83.4	19.7	2.29

Perfiles abiertos normalizados - Perfil L de alas desiguales – Medidas

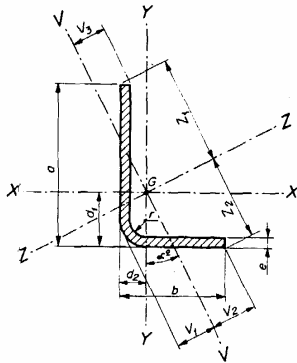

- Siendo:
- A = Área de la sección recta.
 - M = Masa por metro.
 - I = Momento de inercia (referido al eje correspondiente de flexión).
 - W = Momento resistente (referido al eje correspondiente de flexión).
 - i = $\sqrt{I/A}$ = Radio de giro (referido al eje correspondiente de flexión).
 - d = Distancia del centro de gravedad a la cara exterior.
 - u = Perímetro (superficie por metro lineal).

PERFIL	Dimensiones				A cm ²	M kg/m	u m ² /m	Distancia de los ejes					tag α°		
	a mm	b mm	e mm	r mm				d ₁ cm	d ₂ cm	V ₁ cm	V ₂ cm	V ₃ cm		Z ₁ cm	Z ₂ cm
LF 30 . 20 . 1.5	30	20	1.5	1.6	0.712	0.559	0.0980	0.976	0.466	0.732	1.04	0.565	2.03	1.53	0.464
LF 30 . 20 . 2.0	30	20	2.0	2.5	0.930	0.730	0.0970	1.01	0.490	0.722	1.03	0.583	2.01	1.55	0.468
LF 30 . 20 . 3.0	30	20	3.0	3.0	1.35	1.06	0.0961	1.05	0.532	0.730	1.01	0.616	1.99	1.58	0.468
LF 40 . 20 . 2.0*	40	20	2.0	2.5	1.13	0.887	0.117	1.45	0.421	0.697	1.18	0.491	2.57	1.83	0.287
LF 40 . 20 . 3.0*	40	20	3.0	3.0	1.65	1.30	0.116	1.50	0.462	0.714	1.15	0.531	2.53	1.86	0.286
LF 50 . 25 . 2.0*	50	25	2.0	2.5	1.43	1.12	0.147	1.78	0.504	0.867	1.49	0.592	3.23	2.26	0.286
LF 50 . 25 . 3.0*	50	25	3.0	3.0	2.10	1.65	0.146	1.83	0.545	0.884	1.46	0.632	3.20	2.30	0.285
LF 60 . 30 . 3.0*	60	30	3.0	3.0	2.55	2.00	0.176	2.16	0.628	1.05	1.77	0.733	3.86	2.73	0.284
LF 60 . 30 . 4.0*	60	30	4.0	6.0	3.30	2.59	0.173	2.24	0.679	1.04	1.71	0.786	3.80	2.80	0.292
LF 60 . 40 . 3.0	60	40	3.0	3.0	2.85	2.24	0.196	1.95	0.931	1.47	2.09	1.13	4.07	3.06	0.463
LF 60 . 40 . 4.0	60	40	4.0	6.0	3.70	2.91	0.193	2.02	0.984	1.42	2.04	1.17	4.02	3.12	0.472
LF 70 . 40 . 3.0	70	40	3.0	3.0	3.15	2.47	0.216	2.38	0.856	1.44	2.27	1.02	4.64	3.30	0.354
LF 70 . 40 . 4.0	70	40	4.0	6.0	4.10	3.22	0.213	2.46	0.908	1.41	2.21	1.07	4.58	3.36	0.361
LF 70 . 50 . 5.0	70	50	5.0	8.0	5.52	4.34	0.231	2.32	1.28	1.76	2.42	1.52	4.73	3.80	0.535
LF 80 . 40 . 4.0*	80	40	4.0	6.0	4.50	3.53	0.233	2.91	0.845	1.38	2.34	0.988	5.13	3.67	0.289
LF 80 . 40 . 5.0*	80	40	5.0	8.0	5.52	4.34	0.231	2.97	0.893	1.38	2.29	1.04	5.07	3.73	0.293
LF 90 . 60 . 5.0	90	60	5.0	8.0	7.02	5.51	0.291	2.98	1.43	2.13	3.08	1.72	6.06	4.64	0.471
LF 100 . 50 . 5.0*	100	50	5.0	8.0	7.02	5.51	0.291	3.64	1.06	1.72	2.91	1.24	6.40	4.59	0.290
LF 100 . 50 . 6.0*	100	50	6.0	10.0	8.30	6.52	0.289	3.71	1.11	1.72	2.86	1.29	6.35	4.65	0.293
LF 120 . 60 . 5.0*	120	60	5.0	8.0	8.52	6.69	0.351	4.30	1.22	2.06	3.53	1.44	7.73	5.46	0.289
LF 120 . 60 . 6.0*	120	60	6.0	10.0	10.1	7.93	0.349	4.37	1.27	2.06	3.49	1.49	7.68	5.52	0.291
LF 140 . 60 . 6.0	140	60	6.0	10.0	11.3	8.87	0.389	5.29	1.17	1.99	3.68	1.37	8.76	6.22	0.226
LF 150 . 80 . 6.0	150	80	6.0	10.0	13.1	10.3	0.449	5.25	1.66	2.78	4.61	1.97	9.79	6.94	0.321
LF 200 . 100 . 6.0	200	100	6.0	10.0	17.3	13.6	0.589	7.03	1.94	3.42	5.98	2.30	13.0	8.98	0.287

(*) Perfil utilizable en edificación.

Perfiles abiertos normalizados - Perfil L de alas desiguales – Momentos

PERFIL	Referido al eje X-X			Referido al eje Y-Y			I_{xy} cm ⁴	Referido al eje Z-Z			Referido al eje V-V		
	I_x cm ⁴	W_x cm ³	i_x cm	I_y cm ⁴	W_y cm ³	i_y cm		I_z cm ⁴	W_z cm ³	i_z cm	I_v cm ⁴	W_v cm ³	i_v cm
LF 30 . 20 . 1.5	0.673	0.333	0.972	0.249	0.162	0.591	0.251	0.789	0.388	1.05	0.132	0.127	0.431
LF 30 . 20 . 2.0	0.864	0.433	0.964	0.318	0.211	0.585	0.328	1.02	0.505	1.05	0.165	0.160	0.421
LF 30 . 20 . 3.0	1.22	0.625	0.948	0.442	0.301	0.572	0.464	1.43	0.721	1.03	0.225	0.223	0.408
LF 40 . 20 . 2.0*	1.90	0.746	1.30	0.344	0.218	0.552	0.487	2.04	0.796	1.34	0.204	0.174	0.425
LF 40 . 20 . 3.0*	2.71	1.08	1.28	0.480	0.312	0.539	0.693	2.91	1.15	1.33	0.282	0.246	0.413
LF 50 . 25 . 2.0*	3.81	1.18	1.63	0.692	0.347	0.696	0.969	4.09	1.26	1.69	0.415	0.279	0.539
LF 50 . 25 . 3.0*	5.48	1.73	1.62	0.980	0.501	0.683	1.39	5.88	1.84	1.67	0.583	0.399	0.527
LF 60 . 30 . 3.0*	9.69	2.52	1.95	1.74	0.735	0.827	2.46	10.4	2.69	2.02	1.05	0.590	0.640
LF 60 . 30 . 4.0*	12.3	3.26	1.93	2.20	0.948	0.816	3.22	13.2	3.48	2.00	1.26	0.736	0.617
LF 60 . 40 . 3.0	10.8	2.66	1.94	3.98	1.30	1.18	4.01	12.6	3.11	2.10	2.13	1.02	0.864
LF 60 . 40 . 4.0	13.8	3.46	1.93	5.07	1.68	1.17	5.27	16.2	4.04	2.09	2.58	1.27	0.835
LF 70 . 40 . 3.0	16.4	3.56	2.28	4.15	1.32	1.15	4.97	18.2	3.92	2.40	2.39	1.05	0.871
LF 70 . 40 . 4.0	21.0	4.63	2.26	5.30	1.71	1.14	6.54	23.4	5.11	2.39	2.93	1.33	0.846
LF 70 . 50 . 5.0	27.7	5.91	2.24	12.1	3.25	1.48	11.7	33.9	7.18	2.48	5.85	2.41	1.03
LF 80 . 40 . 4.0*	30.3	5.95	2.60	5.49	1.74	1.10	7.84	32.6	6.36	2.69	3.22	1.38	0.846
LF 80 . 40 . 5.0*	36.6	7.29	2.58	6.59	2.12	1.09	9.62	39.4	7.77	2.67	3.77	1.65	0.826
LF 90 . 60 . 5.0	59.4	9.86	2.91	22.0	4.81	1.77	22.6	70.0	11.6	3.16	11.3	3.68	1.27
LF 100 . 50 . 5.0*	73.9	11.6	3.24	13.4	3.40	1.38	19.2	79.5	12.4	3.36	7.81	2.68	1.06
LF 100 . 50 . 6.0*	86.2	13.7	3.22	15.6	4.00	1.37	22.7	92.9	14.6	3.34	8.90	3.11	1.04
LF 120 . 60 . 5.0*	130	16.9	3.91	23.7	4.97	1.67	33.6	140	18.1	4.05	14.0	3.97	1.28
LF 120 . 60 . 6.0*	153	20.1	3.89	27.7	5.86	1.66	39.8	165	21.4	4.04	16.1	4.63	1.26
LF 140 . 60 . 6.0	233	26.8	4.54	28.8	5.96	1.60	48.8	244	27.9	4.65	17.7	4.82	1.25
LF 150 . 80 . 6.0	314	32.2	4.90	67.3	10.6	2.27	88.3	342	35.0	5.11	38.9	8.44	1.72
LF 200 . 100 . 6.0	745	57.5	6.56	137	16.9	2.81	190	800	61.5	6.80	82.0	13.7	2.18

(*) Perfil utilizable en edificación.